

**MODERN  
PRECISION  
RIFLE**

---

**OWNERS MANUAL**





## IMPORTANT

READ ALL INSTRUCTIONS AND WARNINGS ON THIS PAGE BEFORE USING THE FIREARM.



## WARNING: STRONG MAGNET



THE STOCK OF THIS PRODUCT CONTAINS A POWERFUL MAGNET (14,900 GAUSS) THAT COULD ADVERSLY AFFECT THE FUNCTIONING OF PACEMAKERS AND IMPLANTED HEART DEFIBRILATORS. MAGNETS MAY ALSO ADVERSLY AFFECT OTHER MEDICAL DEVICES.



IF YOU HAVE ANY SUCH DEVICES, CONSULT YOUR PHYSICIAN BEFORE HANDLING OR USING THIS PRODUCT.



## WARNING

CHILDREN ARE ATTRACTED TO AND CAN OPERATE FIREARMS THAT CAN CAUSE SEVERE INJURIES OR DEATH.

PREVENT CHILD ACCESS BY ALWAYS KEEPING GUNS LOCKED AWAY AND UNLOADED WHEN NOT IN USE. IF YOU KEEP A LOADED FIREARM WHERE A CHILD OBTAINS AND IMPROPERLY USES IT, YOU MAY BE FINED OR SENT TO PRISON.



## ADVERTENCIA

LOS NIÑOS SON ATRAÍDOS POR Y PUEDEN OPERAR ARMAS DE FUEGO QUE PUEDEN CAUSAR LESIONES GRAVES O LA MUERTE.

EVITE EL ACCESO DE NIÑOS MANTENIENDO SIEMPRE LAS ARMAS BLOQUEADAS Y DESCARGADAS CUANDO NO ESTÉN EN USO. SI MANTIENE UN ARMA DE FUEGO CARGADA DONDE UN NIÑO OBTIENE Y LA USA INDEBIDAMENTE, SE LE PUEDE MULTAR O ENVIAR A PRISIÓN.

## **LIMITED LIFETIME WARRANTY**

For the lifetime of the original purchaser, CHRISTENSEN ARMS agrees to correct any defect in the firearm for the original purchaser by repair, adjustment or replacement, at CHRISTENSEN ARMS' sole option, with the same or comparable quality components (or by replacing the firearm at CHRISTENSEN ARMS' option).

**For more info see Page 21.**

## **DISCLAIMER**

Christensen Arms delivers a firearm free of defects. Our guarantee requires that firearm owners safely handle, properly break-in and properly maintain the firearm. Improper use or owner modifications to the firearm voids the guarantee and warranty.

**For more info see Page 21.**

## **MUZZLE BRAKE RECOMMENDATIONS**

1. While cleaning rifle, clean baffles in muzzle brake.
2. Use ear protection when discharging your rifle due to the increased volume caused by the muzzle brake.
3. Christensen Arms barrels with a cerakote finish are built with a "seamless" removable muzzle brake. However, removing the muzzle brake can have a permanent effect on the look and finish of the barrel. Reinstalling the brake may also require the use of shims to clock the brake back into the correct position.

**BARREL BREAK IN PROCEDURES P.11**

**BARREL CLEANING PROCEDURES P.14**

# CONTENTS

---

02 RULES OF SAFETY

---

03 BOLT RIFLE STRUCTURE MODEL

---

04 SAFETY FEATURES

---

05 GENERAL INFORMATION

---

06 AMMUNITION

---

08 ASSEMBLY

---

09 LOADING

---

10 LOADING DETACHABLE MAGAZINE

---

11 CHAMBERING, FIRING, BARREL BREAK-IN

---

12 UNLOADING THE FIREARM

---

13 DISASSEMBLY

---

14 CLEANING

---

15 REASSEMBLY

---

16 ADJUSTMENTS

---

17 FOLDING STOCK

---

18 RECEIVER ASSEMBLY

---

19 RIFLE ASSEMBLY

---

20 SAFE AND LONG-TERM STORAGE

---

20 PRODUCT REGISTRATION

---

21 WARRANTY, GUARANTEE AND DISCLAIMER

# THIS IS CHRISTENSEN ARMS

---

The premise is simple: better materials,  
advanced processes, and emphasis on  
breaking with tradition.

---

COMPOSITES  
EXCELLENCE  
SINCE 1995



# SAFETY FIRST, IT IS YOUR RESPONSIBILITY

---

Treat every gun as if it is a loaded gun AT ALL TIMES!

---

Always keep the muzzle pointed in a safe direction.

---

Never point your firearm at anything that you do not intend to shoot.

---

Keep your finger off the trigger and out of the trigger guard until you are aiming at your target and ready to shoot.

---

Always keep and carry your firearm with an empty chamber until you intend to shoot.

---

Firearms should be unloaded when not in use.

---

Be sure of your target and backstop before you shoot. Analyze what your bullet will hit if it misses or goes through the target.

---

Never shoot at hard, flat surfaces or water.

---

Bullets can ricochet.

---

Always wear hearing and eye protection when shooting.

---

Discharging firearms in poorly ventilated areas, cleaning firearms or handling ammunition may result in exposure to lead, a substance known to be associated with birth defects, reproductive harm, and other serious injuries. Make sure you have adequate ventilation at all times. Wash hands after handling firearms or ammunition.

---

Make sure your barrel is clear of all obstructions including (but not limited to) excessive oil, grease, cleaning patches, debris, etc. before shooting.

---

Use only clean, high quality factory loaded ammunition in good condition. Christensen Arms does not encourage the use of hand-loaded ammunition; any such use voids the Christensen Arms warranty.

---

Do not alter or modify your firearm.

---

Do not try to change your firearm's trigger pull as alterations of trigger pull can affect sear engagement and can cause accidental firing.

---

Do not disassemble your firearm's trigger group. Any alteration or adjustment to the trigger group could result in accidental firing causing serious injury or death.

---

Store firearms and ammunition separately, and in a safe place out of reach of children.

---

In case of malfunction, STOP! Review this manual to identify and resolve the problem. If you cannot resolve the problem please contact Christensen Arms immediately.

# BOLT RIFLE STRUCTURE MODEL

Congratulations on your choice of a Christensen Arms rifle. With proper care, your rifle will give you many years of dependable use. You will find the serial number of the rifle on the left side of the receiver.

Always store your rifle unloaded in a secure, dry place, where it will not be damaged and where only authorized persons can access it. Keep cartridges stored separately and securely.

**DISCLAIMER: YOUR RIFLE MAY DIFFER FROM THOSE SHOWN THROUGHOUT THE MANUAL, DEPENDING ON OPTIONS.**

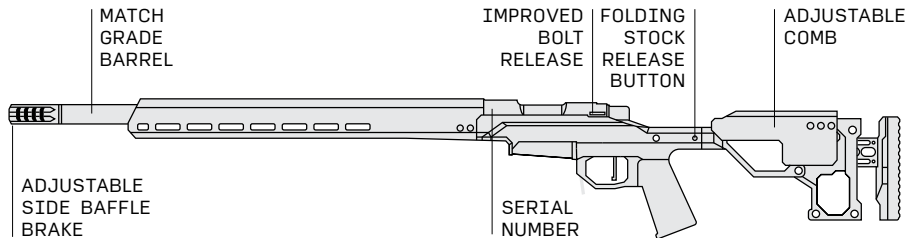
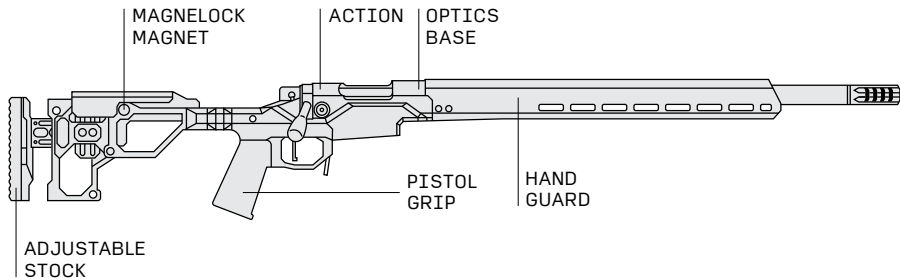

## SAFETY FEATURES

Your safety lever is located to the right of the bolt shroud (right handed rifles). The safety mechanism provides some degree of protection from accidental or unintentional discharge under normal usage when properly engaged and in good working condition.

DO NOT RELY on the safety mechanism exclusively for safety and accident prevention. Always follow proper rules of safety and common sense.

To engage the safety, move the safety lever all the way back to the “S” position.

Keep the safety in the “S” position at all times. ONLY when you are ready to fire the rifle, push the safety lever to the “F” position. Do not touch the trigger while moving the safety lever. Keep the area inside the trigger guard clear and finger off the trigger until you are ready to fire the rifle. Never pull the trigger when the safety lever is in the “S” position.

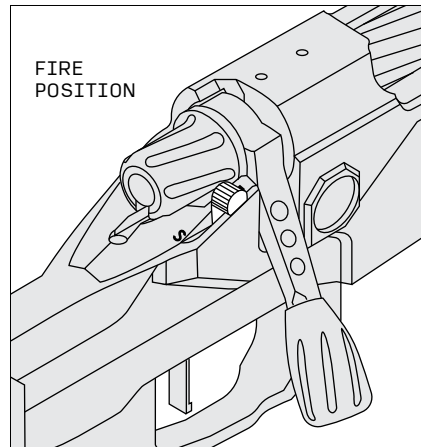
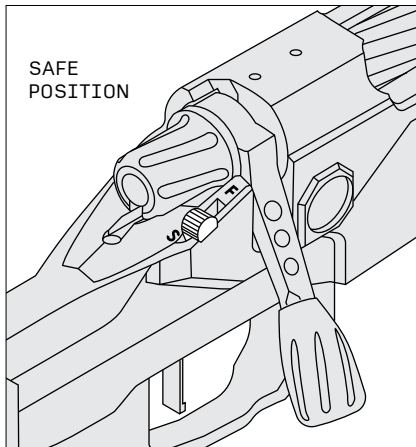



# GENERAL INFORMATION

All Christensen Arms firearms are manufactured to perform at a high degree of accuracy, reliability and durability.

**WARNING: YOUR CHRISTENSEN ARMS FIREARM WAS DESIGNED AND TESTED TO FUNCTION WITH ITS ORIGINAL COMPONENTS. ALTERATIONS TO THE FIREARM IN ANY WAY INCLUDING, BUT NOT LIMITED TO, ALTERING ORIGINAL COMPONENTS OR REPLACING PARTS WITH AFTER-MARKET (NON-CHRISTENSEN ARMS) PARTS OR COMPONENTS CAN CAUSE MALFUNCTIONS AND WILL VOID YOUR WARRANTY. DO NOT USE SUBSTITUTE PARTS UNLESS THEY ARE MANUFACTURED OR RECOMMENDED BY CHRISTENSEN ARMS.**

**PATENT NO.  
5804756, 5692334, 5657568, 8677670**

## TRIGGER SYSTEM

(unless specifically ordered or customized)

The trigger is factory preset with a pull weight of ~3 pounds. After-market triggers should be installed by an experienced gunsmith. If alterations of the trigger are needed, contact Christensen Arms. NOTE: Trigger system has tamper evident material on set screws and adjustments.

## BARREL LIFE

The Christensen Arms Carbon Fiber Wrapped Barrel is an elite choice and upgrade to any platform. The carbon fiber barrel consists of a stainless steel, select match grade barrel. The steel profile is turned to a proprietary contour and then wound in carbon fiber utilizing a patented process. Chambered to match grade specifications, your Christensen Arms carbon barrel will give the accuracy performance enhancements that are desired in a high-end rifle. A few of the benefits to our patented carbon barrel system are listed:

- 1 A lightweight barrel with the accuracy of a target bull barrel.
- 2 Our carbon-fiber barrel is three times stiffer than a steel barrel of equal weight, which reduces flex & harmonics, increasing precision.
- 3 The Christensen Arms patented carbon layup process produces a barrel shell that has zero thermal expansion coefficients, which brings you shot after shot consistency.
- 4 Performs well in any climate or temperature, corrosion resistant.
- 5 Dissipates heat from the stainless steel liner 300% faster than steel.
6. Barrel life can be extended by 25%.

## APPEARANCE

Christensen Arms Bolt Rifles are an industrial product and bears finishes appropriate for its intended purposes. Christensen Arms rifles are all thoroughly test fired before shipping. New rifles will normally show evidence of this firing. If the receiver looks light or uneven in color, which is typically due to dryness, apply a light coat of oil on the metallic surface and this will improve the appearance.

# AMMUNITION

1 Use only high quality, original factory manufactured ammunition. Use only ammunition of the caliber for which your firearm is chambered. The proper caliber is permanently engraved on the barrel of your firearm; never attempt to use ammunition of any other caliber.

2 The use of reloaded, “re-manufactured,” hand loaded or other nonstandard ammunition voids all warranties. Reloading is a science and improperly loaded ammunition can be extremely dangerous. Severe damage to the firearm and serious injury to the shooter or to others may result. Always use ammunition that complies with the industry performance standards established by the Sporting Arms and Ammunition Manufacturers’ Institute, Inc. of the United States (SAAMI).

3 Firearms may be severely damaged, and

serious injury to the shooter or others may result from any condition causing excessive pressure inside the chamber or barrel during firing.

Excessive pressure can be caused by an obstruction in the barrel, propellant powder overloads or by the use of incorrect or defectively assembled cartridges. In addition, the use of a dirty, corroded or damaged cartridge can lead to a burst cartridge case and consequent damage to the firearm and personal injury from the sudden escape of high-pressure propellant gas within the firearm’s mechanism.

4 Immediately stop shooting and check the barrel for a possible obstruction whenever: You have difficulty in, or feel unusual resistance in chambering a cartridge, or A cartridge misfires (does not go off), or The mechanism fails to extract a fired cartridge case, or Unburned grains of propellant powder are discovered spilled in the mechanism, or A shot sounds weak or abnormal. In such cases it is possible that a bullet is lodged part

way down the barrel. Firing a subsequent bullet into the obstructed barrel can cause severe damage to the firearm and cause serious injury to the shooter or bystanders.

5 Bullets can become lodged in the barrel: If the cartridge has been improperly loaded with insufficient propellant, or if the propellant fails to ignite. (Ignition of the cartridge primer alone may push the bullet out of the cartridge case, but usually does not generate sufficient energy to expel the bullet completely from the barrel), or

If the bullet is not properly seated in the cartridge case. When such a cartridge is extracted from the chamber without being fired, the bullet may be left behind in the bore at the point where the rifling begins. Subsequent chambering of another cartridge may push the first bullet further into the bore.

6 If there is any reason to suspect that a bullet is obstructing the barrel, immediately unload the firearm, remove the bolt and look through the bore. It is not sufficient to merely look in

the chamber. A bullet may be lodged some distance down the barrel where it cannot easily be seen. If the bullet can be easily removed with a wood or brass dowel, (using hand pressure only, never “hammer” a bullet lodged in before resuming shooting. If the bullet cannot be dislodged by tapping it with a cleaning rod, take the firearm to a gunsmith.

- 7 Dirt, corrosion, or other foreign matter on a cartridge can impede complete chambering and may cause the cartridge case to burst upon firing. The same is true of cartridges which are damaged or deformed.
- 8 Do not oil cartridges, and be sure to wipe the chamber clean of any oil preservative before commencing to shoot. Oil interferes with the friction between cartridge case and chamber wall that is necessary for safe functioning, and subjects the firearm to stress similar to that imposed by excessive pressure. Lubricant and other foreign matter on cartridges can cause potentially dangerous ammunition malfunctions.
- 9 Use lubricants liberally on the moving parts of your firearm. Avoid excessive spraying of any aerosol gun

care product, especially where it may get on ammunition. All lubricants, and aerosol spray lubricants in particular, can penetrate cartridge primers and cause misfires. Some highly penetrative lubricants can also migrate inside cartridge cases and cause deterioration of the propellant powder; on firing, the powder may not ignite. If only the primer ignites, there is a danger that the bullet may become lodged in the barrel.

**WARNING: IF A BULLET IS IN THE BORE, DO NOT ATTEMPT TO SHOOT IT OUT BY USING ANOTHER CARTRIDGE, OR BY BLOWING IT OUT WITH A BLANK OR ONE FROM WHICH THE BULLET HAS BEEN REMOVED. SUCH TECHNIQUES CAN GENERATE EXCESSIVE PRESSURE, DAMAGE THE FIREARM AND CAUSE SERIOUS PERSONAL INJURY.**

**WARNING: USE OF INCORRECT AMMUNITION CAN CAUSE FIREARM DAMAGE, PERSONAL INJURY OR DEATH. MAKE ABSOLUTELY CERTAIN THAT YOU ARE USING CARTRIDGES DESIGNED FOR YOUR FIREARM. DO NOT FIRE OLD, CORRODED, DEFORMED OR HAND LOADED AMMUNITION. IF YOU HAVE ANY QUESTIONS, CONTACT CHRISTENSEN ARMS BEFORE FIRING.**

**WARNING: DO NOT FIRE SABOT AMMUNITION FROM YOUR RIFLE. THE SABOT COULD LODGE IN YOUR MUZZLE BRAKE CAUSING FIREARM DAMAGE AND POTENTIAL INJURY OR DEATH.**

NOTE: SOME TYPES/BRANDS OF AMMUNITION HAVE UNIQUE CHARACTERISTICS (E.G. EXTREMELY LIGHT OR HEAVY PROJECTILES, PARTICULARLY SOFT CARTRIDGE CASES, PROPELLANT THAT BURNS UNUSUALLY SLOWER OR MORE RAPIDLY), WHICH CAN REDUCE ITS RELIABILITY.

CHRISTENSEN ARMS RECOMMENDS THAT YOU PURCHASE AND TEST A SMALL QUANTITY OF ANY TYPE OF AMMO IN YOUR FIREARM BEFORE YOU BUY LARGE QUANTITIES.

**IF YOU HAVE ANY DOUBTS ABOUT YOUR ABILITY TO HANDLE OR USE THIS FIREARM SAFELY, YOU SHOULD SEEK SUPERVISED INSTRUCTION AND TRAINING. PERSONAL INSTRUCTORS AND GUN SAFETY TRAINING COURSES ARE OFTEN AVAILABLE FROM GUN DEALERS, LAW ENFORCEMENT AGENCIES, GUN CLUBS, AND OTHER SIMILAR LOCATIONS AND GROUPS**

# ASSEMBLY

## INITIAL ASSEMBLY

Your firearm is shipped completely assembled, except the bolt has been removed. Simply insert the bolt into the action. At the front of the bolt there are two lugs. One has a groove and one does not. Match up the grooves on the lug with the grooves on the action.

**WARNING: IF YOU MOUNT A SCOPE TO YOUR RIFLE, MAKE SURE THE SCOPE IS MOUNTED FAR ENOUGH FORWARD SO THAT IT WILL NOT IMPACT YOUR FACE DURING RECOIL. CHECK THE DISTANCE BETWEEN THE SCOPE AND YOUR FACE WHEN YOU ARE IN THE FIRING POSITION. KEEP IN MIND THAT YOUR EYE WILL BE CLOSER TO THE SCOPE WHEN SHOOTING FROM PRONE OR FROM THE BENCH THAN WHEN SHOOTING OFF-HAND. WHEN IN DOUBT INCREASE THE EYE RELIEF.**

## TRIGGER

**Your trigger is adjusted at the factory. All adjustments to the Trigger must be done at our factory.**

**WARNING: READ THIS MANUAL COMPLETELY AS YOU INSPECT YOUR NEW CHRISTENSEN ARMS FIREARM. MAKE SURE YOU UNDERSTAND HOW TO ASSEMBLE, OPERATE, DISASSEMBLE, MAINTAIN AND STORE YOUR FIREARM SAFELY BEFORE YOU USE IT.**

Any time you disassemble and reassemble a firearm, ENSURE THAT THE RIFLE IS UNLOADED AND MAGAZINE IS REMOVED. Then you should conduct a functional check.  
(discussed later in this manual pg. 20)

## INITIAL CLEANING

Clean the bore of your firearm and lubricate the firearm as described in the Maintenance section hereafter. Christensen Arms firearms are typically made more tightly than other bolt rifle designs. A break-in period of 50 rounds allows machined surfaces (including coated surfaces) to smooth out. Lubricate the rifle well before firing.

**WARNING: TO ASSURE PROTECTION FROM CORROSION, YOUR CHRISTENSEN ARMS FIREARM HAS BEEN SHIPPED WITH PRESERVATIVE OIL IN THE BORE. FIRING THE FIREARM WITH PRESERVATIVE IN THE BORE CAN INCREASE PRESSURES, WITH POSSIBLE FIREARM DAMAGE PERSONAL INJURY OR DEATH. CLEAN AND DRY THE BORE BEFORE FIRING YOUR CHRISTENSEN ARMS FIREARM.**

# LOADING

**WARNING: ALWAYS KEEP THE SAFETY IN THE “SAFE” POSITION UNTIL YOU ARE READY TO FIRE THE FIREARM. REMEMBER THAT THE SAFETY IS SIMPLY A MECHANICAL DEVICE, AND AS SUCH, COULD POSSIBLY FAIL. ALWAYS KEEP THE CHAMBER EMPTY AND THE FIREARM POINTED IN A SAFE DIRECTION EVEN WHEN SAFETY IS IN THE SAFE POSITION.**

**WARNING: INJURY, DEATH OR FIREARM DAMAGE CAN RESULT FROM FIRING A FIREARM WITH AN OBSTRUCTION IN THE BORE. BEFORE YOU FIRE MAKE SURE THAT THE BORE IS NOT OBSTRUCTED. NEVER ATTEMPT TO SHOOT OUT A BORE OBSTRUCTION.**

**WARNING: ALWAYS WEAR EYE AND EAR PROTECTION. MAKE SURE THAT BYSTANDERS ALSO WEAR EYE AND EAR PROTECTION.**

**WARNING: HANDLING OF CARTRIDGES AND FIRING FIREARMS MAY EXPOSE YOU TO LEAD. ALWAYS**

**ASSURE THAT THERE IS ADEQUATE VENTILATION. ALWAYS WASH YOUR HANDS AFTER HANDLING AMMUNITION OR AFTER FIRING YOUR FIREARM.**

**WARNING: THIS FIREARM WILL FIRE WITHOUT A MAGAZINE IN IT. ALWAYS MAKE SURE THE CHAMBER IS EMPTY. THE FIREARM SHOULD NOT BE CONSIDERED TO BE SAFE UNLESS THE MAGAZINE IS REMOVED, THE SAFETY IS ON, THE BOLT IS OPEN AND THE CHAMBER IS EMPTY.**

**WARNING: THE FIRED CARTRIDGE CASE MAY BE HOT WHEN IT IS EJECTED FROM THE FIREARM.**

**WARNING: IF THE FIREARM FAILS TO FIRE WHEN THE TRIGGER IS PULLED:**

- 1 KEEP THE FIREARM POINTED AT THE TARGET.
- 2 WAIT 15 SECONDS TO ALLOW A POSSIBLE “HANG-FIRE” TO GO OFF.
- 3 REMOVE THE MAGAZINE OR OPEN THE BOTTOM METAL.
- 4 CHECK TO SEE IF THE SAFETY IS ENGAGED BY MISTAKE. IF SO, PUSH THE SAFETY TO THE “FIRE” POSITION, AIM AT INTENDED TARGET AND FIRE.
- 5 IF THE FIREARM STILL DOESN’T FIRE, BE CAUTIOUS AND ASSUME THAT THE CARTRIDGE WILL DISCHARGE WHEN THE BOLT IS OPENED.
- 6 OPEN THE BOLT QUICKLY (WITH THE EJECTION PORT POINTED AWAY FROM YOUR FACE AND BODY) AND UNLOAD THE FIREARM.
- 7 EXAMINE THE FIREARM AND CARTRIDGE CAREFULLY TO IDENTIFY THE CAUSE OF THE MALFUNCTION.

## LOADING DETACHABLE MAGAZINE

The detachable magazine can be loaded when removed from the rifle by pressing the cartridge down into the forward portion of the magazine then sliding back towards the rear. (see images below)

**DUE TO VARIATIONS IN DIAMETERS OF VARIOUS BRANDS OF CARTRIDGES, IT MAY BE POSSIBLE TO FORCE AN ADDITIONAL CARTRIDGE INTO THE MAGAZINE. DOING SO MAY DAMAGE YOUR MAGAZINE AND LEAD TO ELEVATED MALFUNCTION RATES.**

**SEATING THE DETACHABLE MAGAZINE INTO FIREARM**

- 1 Place the safety selector in the “SAFE” position.
- 2 Push the magazine up into the receiver until the magazine catch engages and holds the magazine.
- 3 Pull down on the magazine slightly to make sure it is locked into place.

**CAUTION: KEEP YOUR MAGAZINES CLEAN AND DRY. NEVER POUND THE MAGAZINE INTO THE RIFLE. INSERT THE MAGAZINE COMPLETELY INTO THE RIFLE THEN TUG DOWNWARD TO ASSURE IT IS SECURELY LOCKED INTO PLACE.**

**CAUTION: DO NOT EXCEED MAGAZINE CAPACITIES.**

**NOTE:** The cartridges in a fully loaded magazine can be packed tight and require firm upward pressure to assure that the magazine catch holds the magazine.

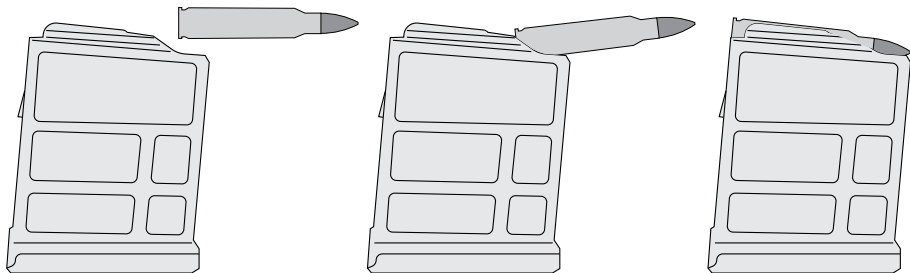

## CHAMBERING

- 1 If bolt is closed, open the bolt by pulling up on the handle.
- 2 When the bolt has stopped rotating, pull bolt back to rear most position.
- 3 Smoothly press bolt forward to chamber the first round
- 4 Close the bolt by lowering the handle all the way down.

**WARNING: KEEP THE SAFETY IN THE "SAFE" POSITION UNTIL YOU ARE READY TO SHOOT.**

**CAUTION: DO NOT REST THE RIFLE ON ITS MAGAZINE WHEN YOU ARE LOADING OR FIRING IT. DOING SO CAN FORCE THE MAGAZINE UP INTO THE RIFLE, REDUCING THE RELIABILITY.**

## FIRING

- 1 Aim at the target.
- 2 Set the safety selector to "FIRE."
- 3 Grip the rifle firmly, and squeeze the trigger increasing the pressure until the shot fires.

When firing, pay attention. If you hear a noticeable difference in sound or recoil, STOP FIRING IMMEDIATELY. Either situation could mean the powder in the round had an incomplete burn or the bullet is stuck in the bore. If this occurs, retract the bolt slowly and remove the fired case. Keep ejection port pointed away from your face and body. Clear the firearm and check for unburned powder in the receiver and bore. Check to see that the bullet or any other obstruction is not stuck in the bore. If there is unburned powder, clean it out before resuming operation. If a bullet or other obstruction is lodged in the bore, do not attempt to remove it. Take the rifle to a qualified gunsmith.

## BARREL BREAK-IN

Christensen Arms recommends the following procedures to break in your new stainless steel match grade barrel.

Go to the link below for complete instructions to break in your new Christensen Arms barrel.

**[CHRISTENSENARMS.COM/BARREL-BREAK-IN](https://christensenarms.com/barrel-break-in)**

**WARNING: FOLLOW ALL OF THE RULES OF SAFE GUN HANDLING ANYTIME YOU HANDLE YOUR FIREARM.**

# UNLOADING THE FIREARM

**WARNING: ALWAYS ASSUME ALL FIREARMS ARE LOADED. ANYTIME YOU HANDLE A FIREARM, YOU SHOULD IMMEDIATELY INSPECT IT TO ASSURE THAT IT IS COMPLETELY UNLOADED.**

**WARNING: YOU MUST KNOW HOW TO UNLOAD AND CLEAR YOUR FIREARM.**

12 Keep your rifle cleared when not in use.

- 1 Place safety selector in the “SAFE” position

NOTICE: If the rifle is not cocked, the lever cannot be moved to the “SAFE” position.

- 2 Remove the magazine by depressing the magazine catch lever and pulling the magazine down.

**CAUTION: THE MAGAZINE MAY FALL FREE WHEN THE MAGAZINE CATCH LEVER IS PRESSED. DON'T ALLOW THE MAGAZINE TO FALL ONTO A HARD SURFACE. DOING SO MAY DAMAGE THE MAGAZINE.**

- 3 Open the bolt to extract any chambered cartridge.

**WARNING: IF THE CARTRIDGE IN THE MAGAZINE OR MAG BOX ARE NOT REMOVED PRIOR TO THIS PROCEDURE, ANY ROUNDS LEFT IN IT WILL BE CHAMBERED, WHICH COULD LEAD TO AN UNINTENTIONAL DISCHARGE. THE RIFLE WILL FIRE WITH A ROUND CHAMBERED AND THE MAGAZINE REMOVED.**

- 1 Always make sure the barrel is free of all obstructions before chambering a cartridge. Firing with an obstruction will cause damage to your rifle and may cause serious injury.
- 2 Open the action and remove the Bolt Assembly.
- 3 Check the barrel for any obstructions or debris by visually inspecting the bore.
- 4 Use a cleaning rod and patch to remove any obstructions. If they are insufficient for the job, take your rifle to a qualified gunsmith.



# DISASSEMBLY

**WARNING: ALWAYS UNLOAD YOUR FIREARM BEFORE CLEANING, LUBRICATION, DISASSEMBLY OR REASSEMBLY.**

**WARNING: ALWAYS WEAR SAFETY GLASSES WHEN DISASSEMBLING, MAINTAINING OR ASSEMBLING YOUR FIREARM.**

## CLEARING THE RIFLE

**IMPORTANT:** Put the safety selector in the “SAFE” position. Remove the magazine, THEN pull the bolt back and check the chamber.

## REMOVE BOLT ASSEMBLY

- 1 Point rifle in safe direction.
- 2 Ensure rifle is not loaded.
- 3 Lift Bolt Handle and pull all the way back.
- 4 While depressing Bolt Release fully, slide the Bolt from the Rifle.

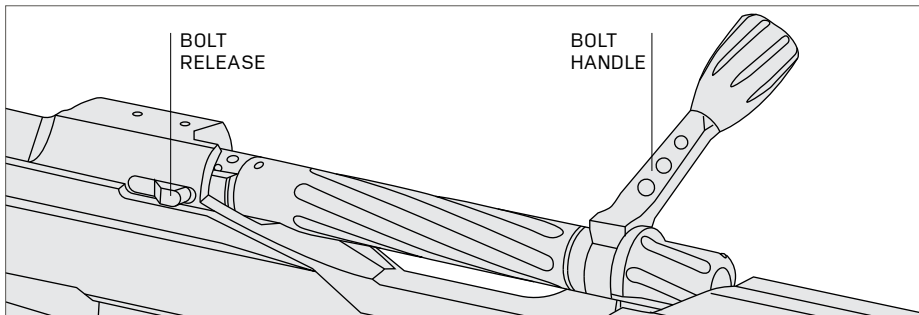

## REMOVING BARRELED ACTION

1. Remove bolt assembly
2. Ensure rifle is not loaded
3. Unbolt and remove the handguard
4. Remove pistol grip from the trigger guard
5. Unbolt the flathead screw at the back of the trigger guard
6. Slide the trigger guard forward to release it from the front taper mortise joint

**NOTE:** If the trigger guard does not slide free, use a nylon head or similar hammer to tap the trigger guard free by striking the rear of the pistol grip mounting lug.

7. Remove the action screws
8. Remove the barreled action from the chassis assembly

**NOTE:** If the barreled action does not remove easily, use a nylon head or similar hammer to tap the top of the handguard mounting lug to begin loosening the barreled action from the chassis assembly.

# CLEANING

Clean your rifle after use. Badly fouled barrels can shoot inaccurately and will corrode much easier than carefully cleaned ones.

- 1 Remove the Bolt Assembly and magazine.
- 2 Place the rifle on its side with the ejection port facing upward or if a gun vise is available, position the rifle right side up in the vise.
- 3 Select the correct caliber cleaning brush and attach to the cleaning rod.
- 4 Put the cleaning brush into the gun solvent.
- 5 ALWAYS push the cleaning/oiling patch from the breech end.
- 6 Push the cleaning brush through the barrel several times.

**CAUTION: DO NOT REVERSE THE DIRECTION OF THE BORE BRUSH WHILE IT IS IN THE BORE.**

- 7 Remove the brush from the cleaning rod and attach the patch tip with a patch. It is advisable to occasionally remove copper fouling from the barrel.

There are various solvents and mechanical cleaners for this purpose.

- 8 Repeat several times, using a clean patch each time, until the patch is not dirty.
- 9 Push a clean patch saturated with oil through the barrel.
- 10 Push a clean dry patch through the barrel to remove excess oil.

## CLEANING LENGTH OF PULL AND COMB HEIGHT ADJUSTMENT BAR

**NOTE: LOP and comb height adjustment can be removed individually**

1. Remove bolt assembly
2. Ensure the rifle is not loaded
3. Remove LOP and comb height clamps with their respective shoulder bolts
4. Slide the recoil pad and cheek rest out of their housing from the stock

## CLEANING SOLVENTS AND LUBRICANTS

The military generally uses a multipurpose chemical called CLP (cleaner, lubricant and preservative) sold commercially as "Break Free." Although it is useful if nothing else is available, armament engineers prefer individual, specialized products. A combination of military RBC (rifle bore cleaner) and LSA (lubricant, semi-fluid, automatic firearms) is superior.

We recommend using high quality solvents to remove metal fouling from the bore.

Lubricate your rifle generously with high quality firearms lubricants.

Under NO condition should any lubricant containing graphite be used with your rifle. Graphite can encourage rapid corrosion in your rifle.

In addition to cleaning solvents and lubricants, the basic cleaning equipment you will need includes a cleaning rod, a brass bore brush, chamber brushes, a toothbrush, patches, pipe cleaners and the most important item: a lint-free cloth.

**NOTE: Do not reverse the direction of the bore brush while it is in the bore.**

## RIFLE MAINTENANCE

- 1 Clean stock with a dampened rag using warm water or mild household cleaner.
- 2 Use gun oil or WD40 on the barrel and wipe dry to restore original look.
- 3 Install the chamber brush on the cleaning rod, dip it in cleaning solvent and insert into the chamber and locking lugs. Clean by pushing and twisting the cleaning rod.
- 4 Take the bore brush off the rod and install a swab holder and swab. Apply cleaning solvent to the swab, and then run it through the chamber and out the muzzle brake (if applicable).
- 5 To remove carbon build up, let the solvent sit then wipe clean. A nylon bore brush may be used with care to remove heavy carbon buildup.
- 6 Wipe the bore dry by running clean swabs all the way through from the chamber to the muzzle brake. **REMEMBER: DO NOT CHANGE DIRECTION OF THE BRUSH WHILE IN THE BORE.**
- 7 Inspect the barrel and stock for cracks, bends or

breaks. Be sure the barrel has no obstructions.

- 8 Lightly lubricate the bore, chamber and outer surface of the barrel.
- 9 With a lubricated swab, run the rod from the receiver to the muzzle brake (if applicable). Do not over lubricate.
- 10 Lubricate the locking lugs.

**WARNING: LEAD MAY BE PRESENT IN THE FOULING OF A DIRTY RIFLE. AVOID CONTACT WITH IT AND CLEAN HANDS AFTERWARD TO AVOID INGESTING LEAD.**

**CAUTION: DO NOT REVERSE THE DIRECTION OF THE BORE BRUSH WHILE IT IS IN THE BORE.**

**WARNING! DO NOT INTERCHANGE BOLTS BETWEEN RIFLES.**

**NOTE:** Do not reverse the direction of the bore brush while it is in the bore.

## REASSEMBLY

Follow disassembly instructions in reverse order.

**REAPPLY THREAD THREAD-LOCKING COMPOUND TO ALL SCREWS**

### TORQUE VALUES

Handguard screws = 20 inch lbs.

Action screws = 65 inch lbs.

Trigger guard screw = 20 inch lbs.

Adjustment screws = 20 inch lbs.

## ADJUSTMENTS

Your new MPR™ comes with an adjustable length of pull and comb height adjustments. By loosening the bolts located on the stock adjustment clamps on the right side of the rifle, you can adjust the length of pull and the comb height. Using a 3/32 Allen wrench simply loosen both bolts for the desired adjustment. Slide the cheek piece or recoil pad to the new location and tighten the bolts. **CAUTION!!! DO NOT OVER TIGHTEN, 20 INCH LBS IS SUFFICIENT.**

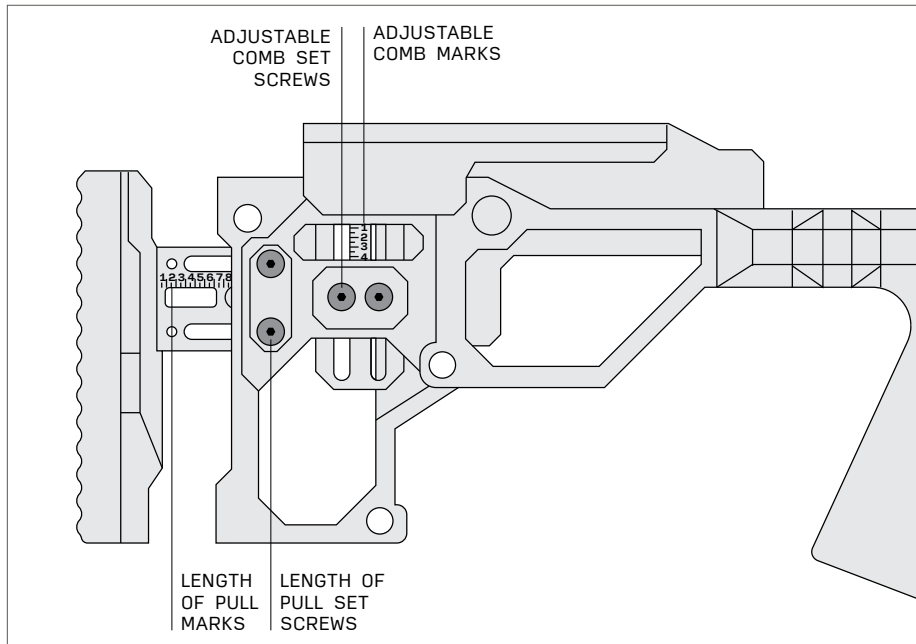

## FOLDING STOCK

The butt-stock of your MPR™ rifle folds away to the right side of the rifle capturing the bolt and stowing in the folded position via our Magnelock™ technology. Simply depress the butt-stock release button on the left side of the stock frame and fold the butt-stock to the right.

To return the stock to the ready to fire position simply grasp the recoil pad and pull it away from the chassis base and snap it into the locked operational position.

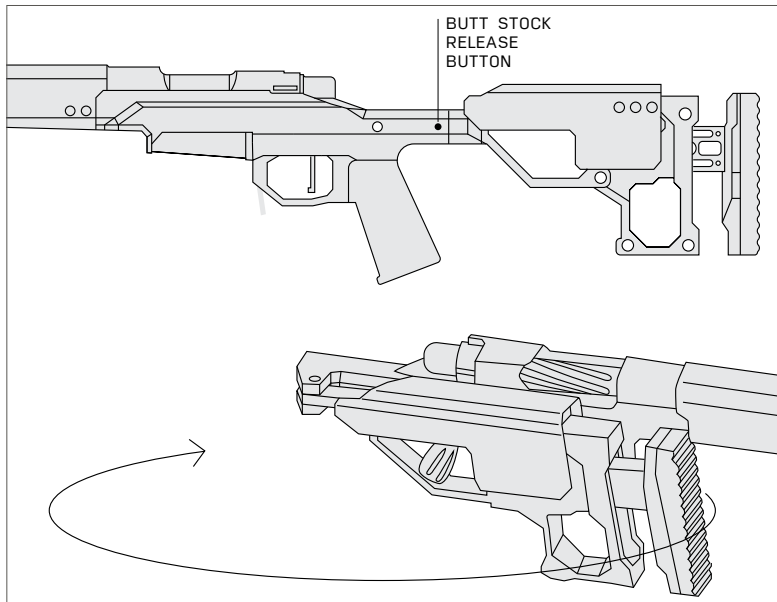

# RECEIVER ASSEMBLY

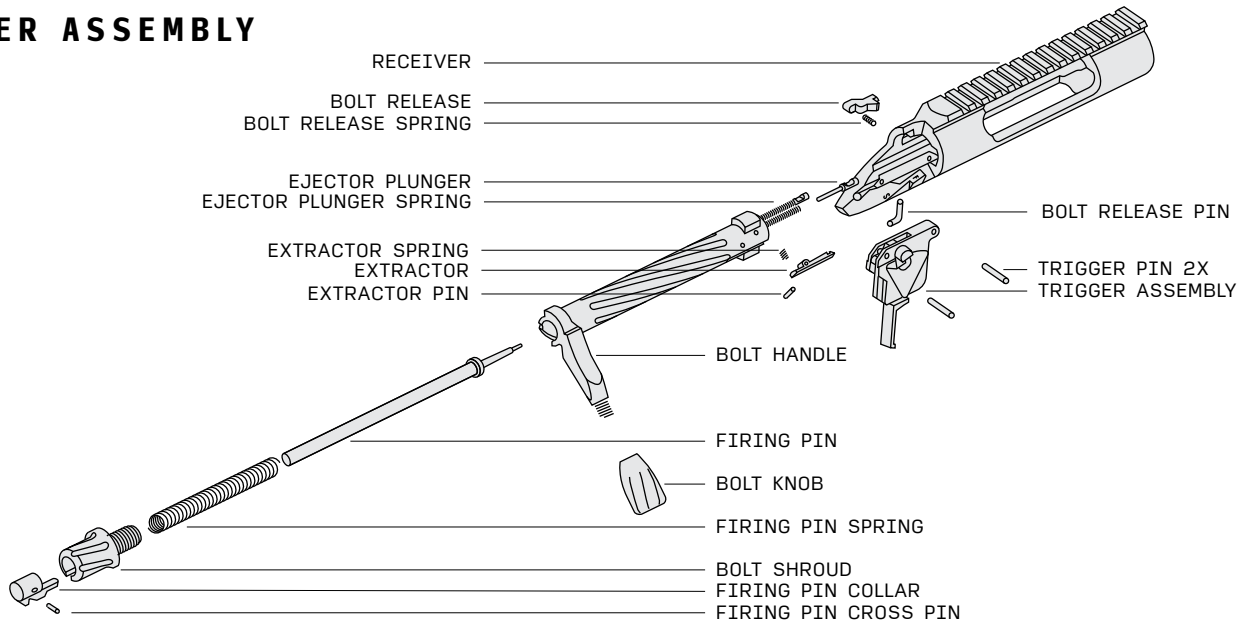

# RIFLE ASSEMBLY

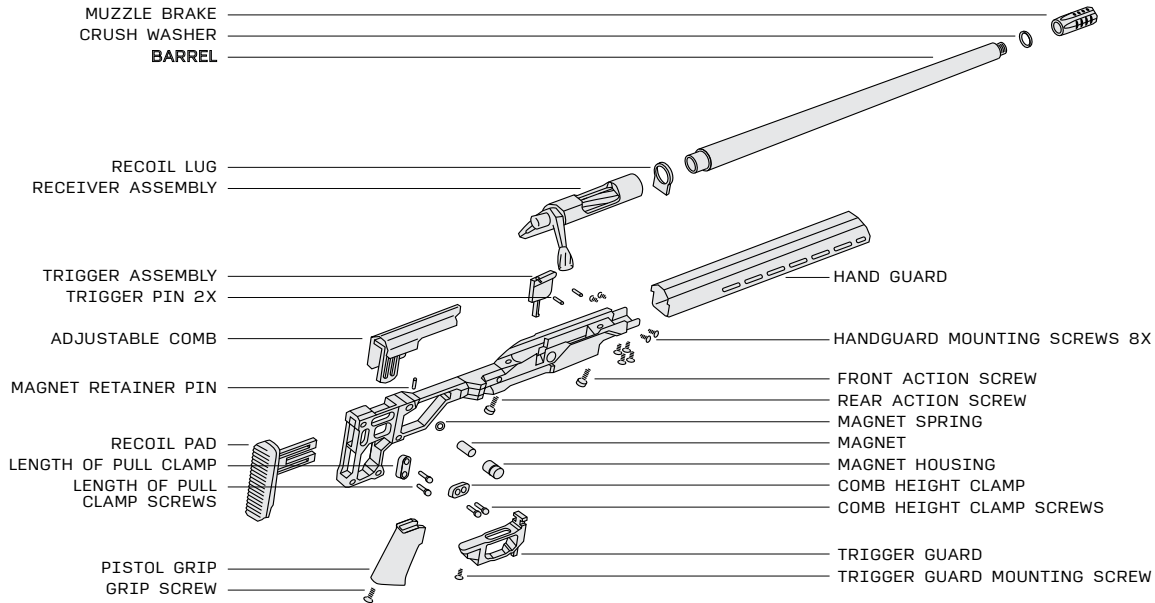

## SAFE STORAGE

Always make sure both the chamber and magazine are unloaded before placing the firearm in storage. Store your rifle in a securely locked gun safe. If you do not have a gun safe, remove the bolt from your rifle and store it separately from the rifle in a secure location. Store your ammunition in a separate location from the rifle and separate from the bolt assembly.

**WARNING: ALWAYS CHECK TO MAKE SURE YOUR FIREARM IS UNLOADED. ALWAYS STORE YOUR FIREARM IN A SAFE LOCATION SEPARATE FROM THE AMMUNITION.**

**WARNING: IF YOU HAVE MORE THAN ONE SIMILAR FIREARM, MAKE SURE THAT YOU SPECIFICALLY IDENTIFY THE REMOVED ASSEMBLY WITH ITS ORIGINAL FIREARM AS THE ASSEMBLIES MAY NOT BE INTER-CHANGEABLE.**

## LONG TERM STORAGE

### **CLEAN YOUR RIFLE WELL AND APPLY A GOOD QUALITY PRESERVATIVE.**

It is at least theoretically possible for some springs to take a set during prolonged storage. To preclude this possibility, Christensen Arms offers the following recommendations regarding long term storage of your firearm.

### **CLEAR ALL CARTRIDGES FROM YOUR FIRE-ARMS**

### **REMOVE THE DETACHABLE MAGAZINE IF APPLICABLE**

### **REMOVE THE BOLT AND STORE SEPARATELY**

### **IT IS ALWAYS BEST TO STORE YOUR MAGAZINES EMPTY**

When you're taking your firearm out of long term storage, remove the preservative and lubricate as stated elsewhere in this manual.

## PRODUCT REGISTRATION

Thank you for choosing a Christensen Arms firearm. Years of dedication and innovation have led to this gun, and we hope you'll enjoy it as much as we do. For the most complete service and to stay up to date with our Christensen Arms owners program, please take the time to register your firearm with us:

**[WWW.CHRISTENSENARMS.COM/REGISTER](http://WWW.CHRISTENSENARMS.COM/REGISTER)**



# WARRANTY AND GUARANTEE INFORMATION

## WARRANTY

CHRISTENSEN ARMS warrants that the enclosed firearm was originally manufactured free of defects in material, workmanship and mechanical function. For the lifetime of the original purchaser, CHRISTENSEN ARMS agrees to correct any defect in the firearm for the original purchaser by repair, adjustment or replacement, at CHRISTENSEN ARMS' sole option, with the same or comparable quality components (or by replacing the firearms at CHRISTENSEN ARMS' option), subject to the limitations detailed below.

This limited warranty is null and void if the firearm has been misused; damaged (by accident or abuse); fired with improper ammunition; fired with an obstruction in the barrel; damaged through failure to provide reasonable and nec-

essary maintenance as described in the manual accompanying the firearm; or if unauthorized repair or any alteration, including of a cosmetic nature, has been performed on the firearm by a party other than CHRISTENSEN ARMS. This limited warranty does not apply to normal wear and tear of any parts.

Subject to the foregoing, this limited warranty confers the right to have the covered firearm or its parts repaired, adjusted or replaced exclusively upon the original purchaser, which right is not transferable to any other person.

No implied warranties of any kind are made herein and this warranty does not apply to any accessory items attached or appurtenant to the firearm.

In no event shall CHRISTENSEN ARMS be liable for any incidental or consequential damages arising from or in connection with this limited warranty.

## GUARANTEE

This rifle is covered by a Sub-MOA accuracy guarantee. Customer is responsible to ensure proper break-in of the firearm during the warranty period, select appropriate ammunition, ensure proper lubrication and use proper conditions.

## DISCLAIMER

Christensen Arms® delivers a firearm free of defects. Our guarantee requires that firearm owners safely handle, properly break in, and properly maintain the firearm. Improper use or owner modifications to the firearm voids the guarantee and warranty.





**ADDRESS**

550 N CEMETERY RD  
GUNNISON, UT  
84634

**EMAIL**

SALES@  
CHRISTENSENARMS.COM

**LOCAL**

435.528.7999

**FREE**

888.517.8855

**FAX**

435.528.5773

